

NOTES:

1.) FOLLOWS CODE CMR 248 10.0

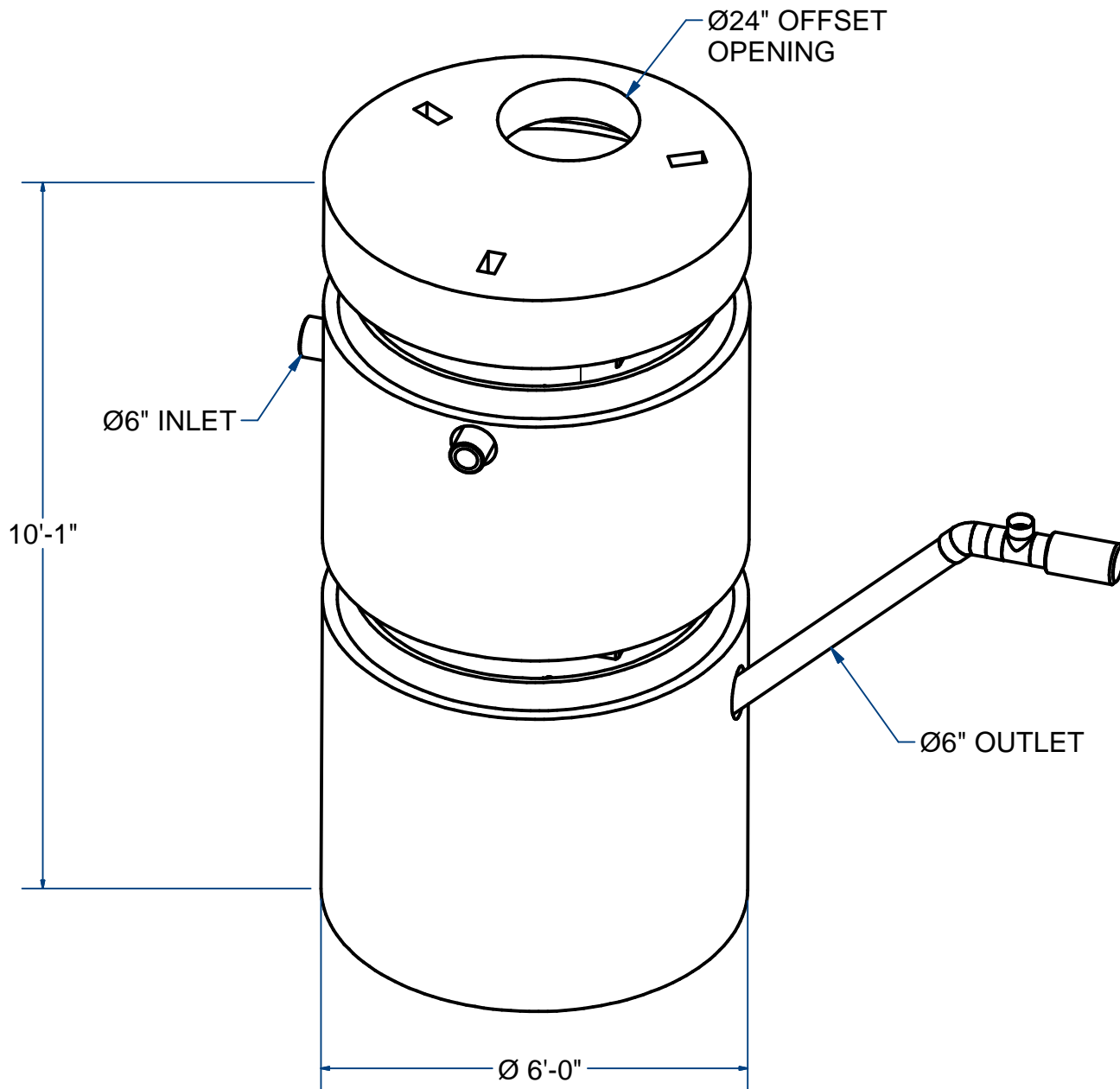

MASS GAS & OIL SEPARATOR

(5') 60" ID

H20

ACME-SHOREY

PRECAST CONCRETE PRODUCTS

NOTES:

- 1.) SEAM SEALED WITH FLEXIBLE BUTYL RUBBER SEALANT.
- 2.) ALL PIPE PENETRATIONS TO BE SEALED WITH HYDRAULIC CEMENT.
- 3.) INVERTS ARE TO ID PIPE SIZE.
- 4.) FOLLOWS CODE 248 CMR 10.0

C (I.D.)	HEIGHT	INLET	A	B
5'-0"	10'-1"	Ø 6"	3'-6"	3'-0"

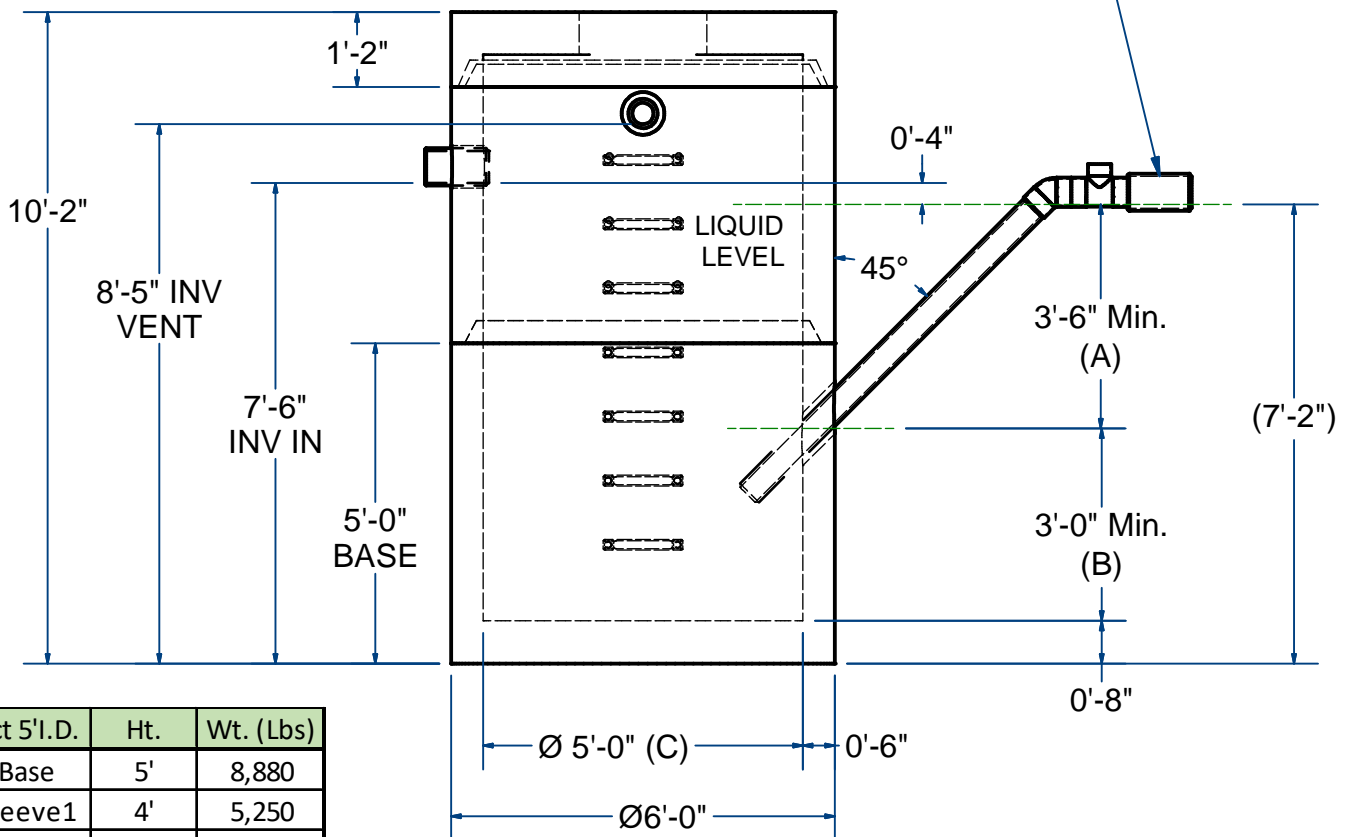
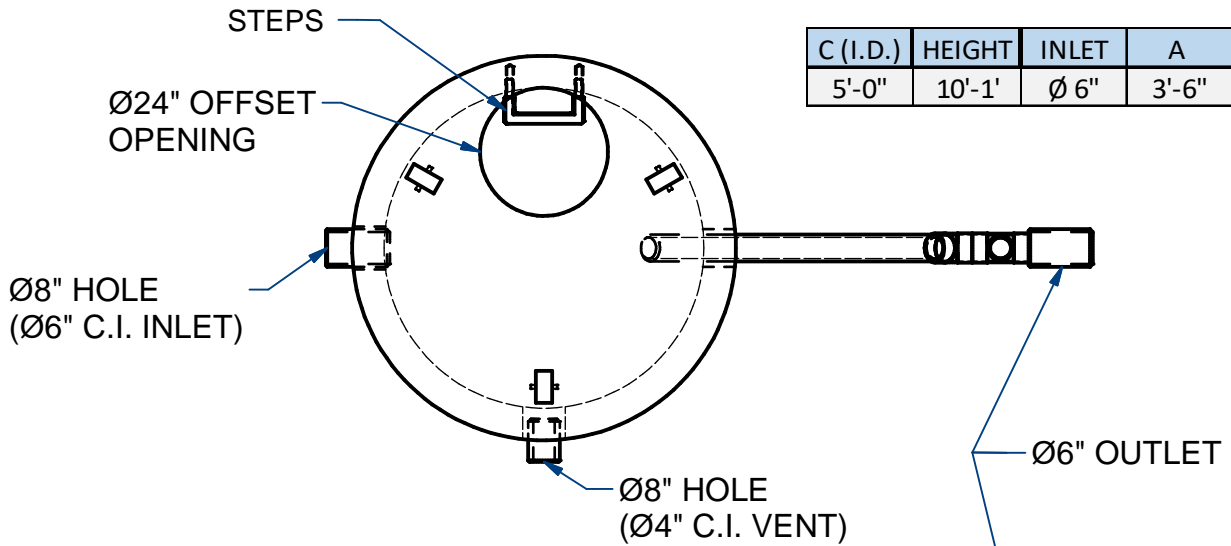

Sct 5'I.D.	Ht.	Wt. (Lbs)
Base	5'	8,880
Sleeve1	4'	5,250
Flat Top	13"	2,770
		16,900

NAME: 5' MASS GAS & OIL SEPARATOR

H20

ITEM# 60MGOS10

Concrete Minimum Strength: 5,000 p.s.i. at 28 days
 Steel Reinforcement: ASTM A615, Grade 60
 Design Loading: standard units - AASHTO - H20

WEIGHT 16,900 Lbs

C

DATE: 10-15-20

Ch 18 Pg 5.2 Sht 2 of 2