

# ACME-SHOREY

PRECAST CONCRETE PRODUCTS

WWW.ACMESHOREY.COM

PHONE (508) 548-9607

FAX (508) 548-1664

CARVER, MA

334 TREMONT STREET

HARWICH, MA

36 GREAT WESTERN ROAD

## NOTES:

- 1.) SEAM SEALED WITH FLEXIBLE BUTYL RUBBER SEALANT.

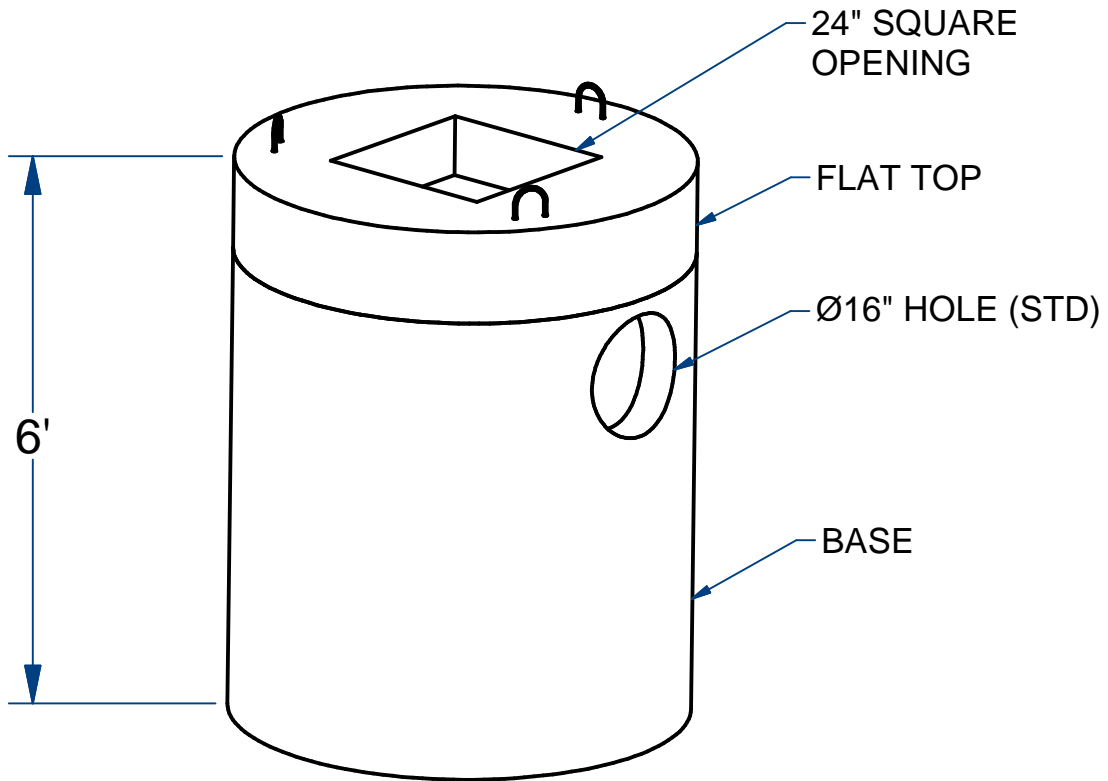

**CATCH BASIN , 4' ID**  
**24" X 24" SQUARE**  
**CONCENTRIC FLAT TOP**  
**3' SUMP**

ITEM# CB4361SQFT

Wt. 7050 Lbs

18-1.3

Sht 1 of 2

# ACME-SHOREY

PRECAST CONCRETE PRODUCTS

**NOTES:**

- 1.) SEAM SEALED WITH FLEXIBLE BUTYL RUBBER SEALANT.

CB4361SQFT		
Each Section 4'ID	Ht.	Wt ea. (Lbs)
Base	60"	5,400
Flat Top	12"	1,650
		7,050

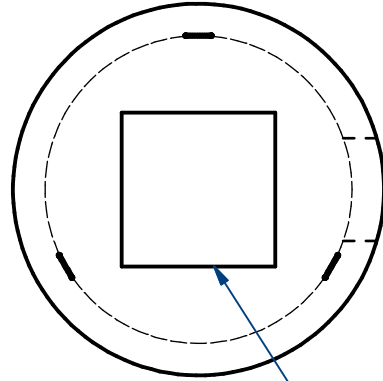

24" SQUARE CONC. OPENING

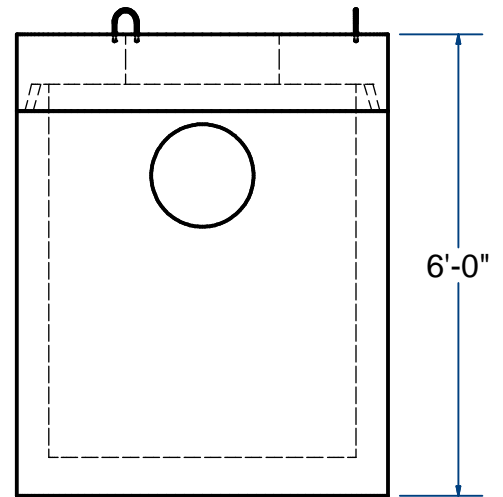
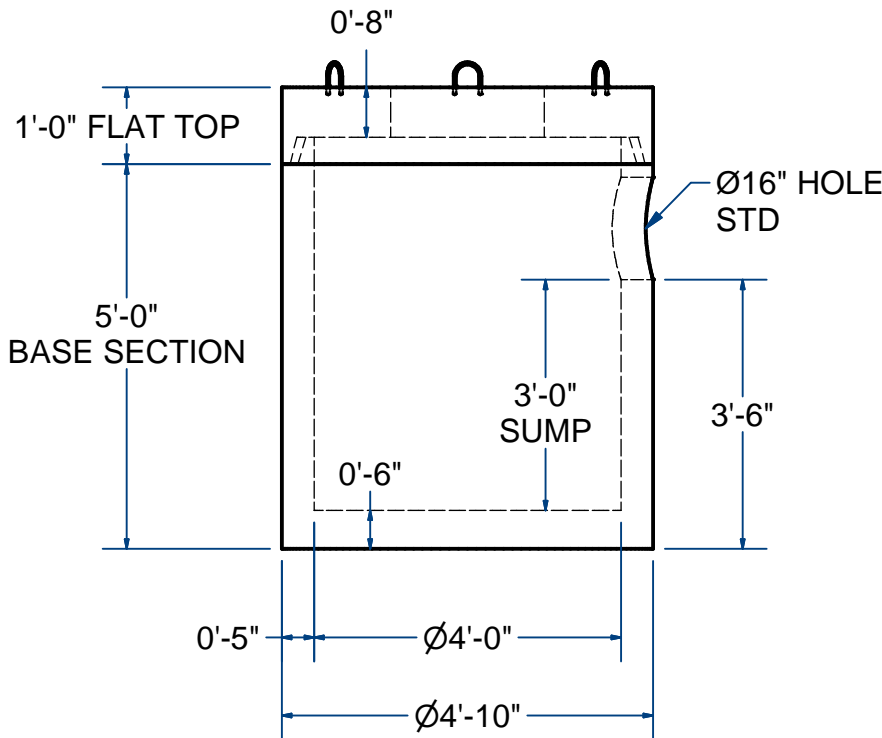

**NAME: CATCH BASIN, 4'ID, FLAT TOP, 3' SUMP**  
(24" X 24" SQUARE CONCENTRIC OPENING)

**H-20**

**ITEM# CB4361SQFT**

CONCRETE MIN. STRENGTH: 5,000 PSI @ 28 DAYS  
STEEL REINFORCEMENT: ASTM A615, GRADE 60  
DESIGN LOADING: STANDARD UNITS-AASHTO-H20

MANHOLES DESIGNED & FABRICATED  
IN ACCORDANCE WITH AND CONFORMING  
TO ASTM C478 PRECAST CONCRETE  
MANHOLE SECTIONS.

CH

DATE: 11-3-2020