

ACME-SHOREY

PRECAST CONCRETE PRODUCTS

WWW.ACMeshOREY.COM

PHONE (508) 548-9607

FAX (508) 548-1664

CARVER, MA
334 TREMONT STREET

HARWICH, MA
36 GREAT WESTERN ROAD

NOTES:

- 1.) SEAM SEALED WITH FLEXIBLE BUTYL RUBBER SEALANT.

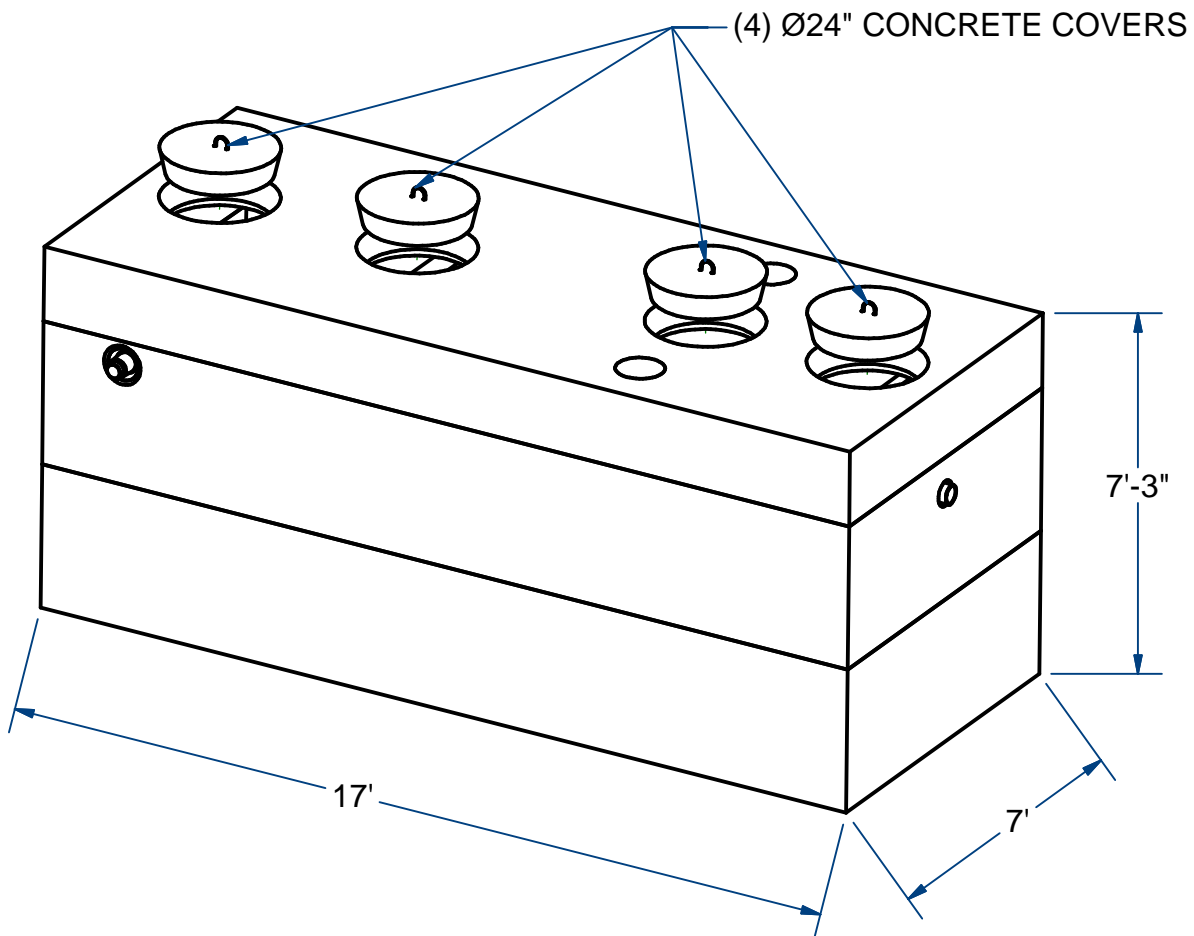

FOR PROCESS INFO
PLEASE CONTACT:

BIO-MICROBICS **FAST** wastewater
(800) 753-3278 treatment systems
with SFR.

DISTRIBUTOR:
J&R Sales & Service
Raynham, Ma. 02767
(508) 823-9566
www.jrsalesinc.com

FAST TANK 1.5 INTERNAL MOUNT H20

ITEM# FTIM1.5

Wt. 45,000 Lbs

14-2.3

Sht 1 of 2

ACME-SHOREY

PRECAST CONCRETE PRODUCTS

NOTES:

- SEAM SEALED WITH FLEXIBLE BUTYL RUBBER SEALANT.

Each Sect.	Ht.	Wt (Lbs)
Base	34.5"	19,000
sleeve	34.5"	11,500
Top ,EXT	18"	14,500
		45,000

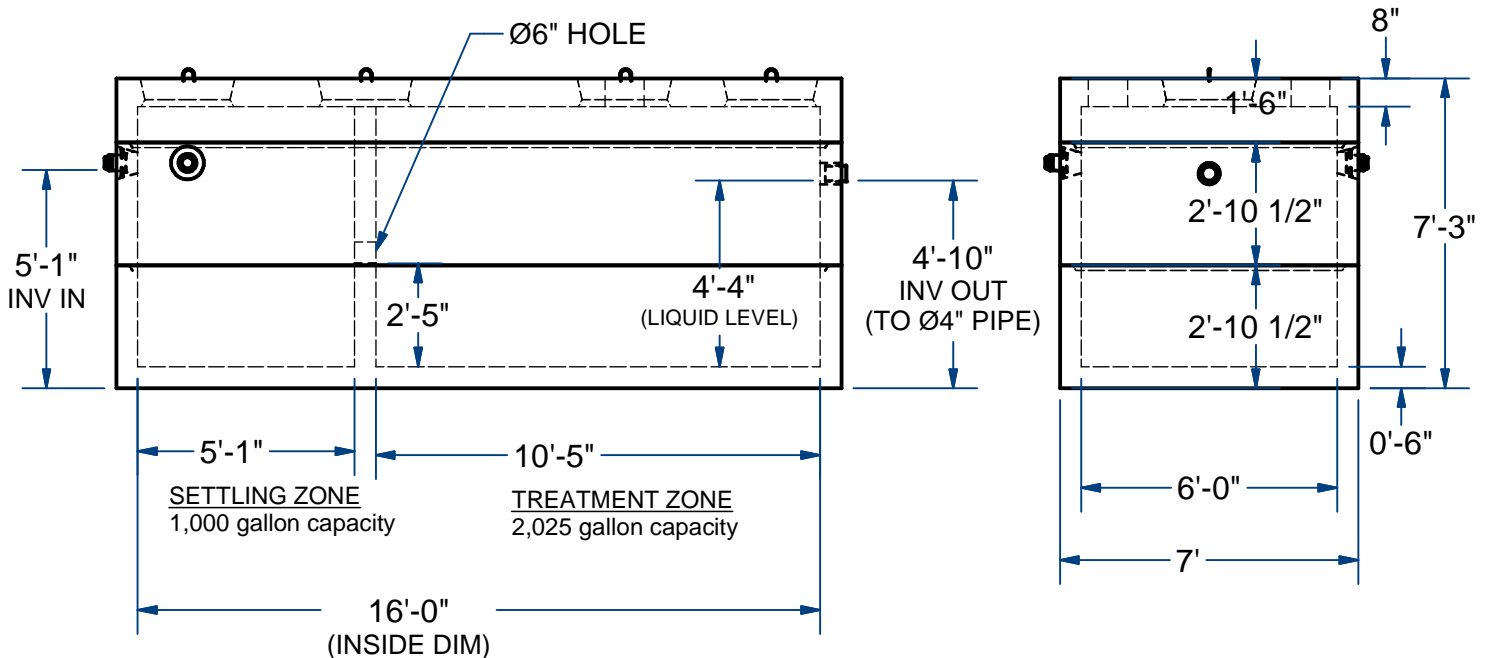
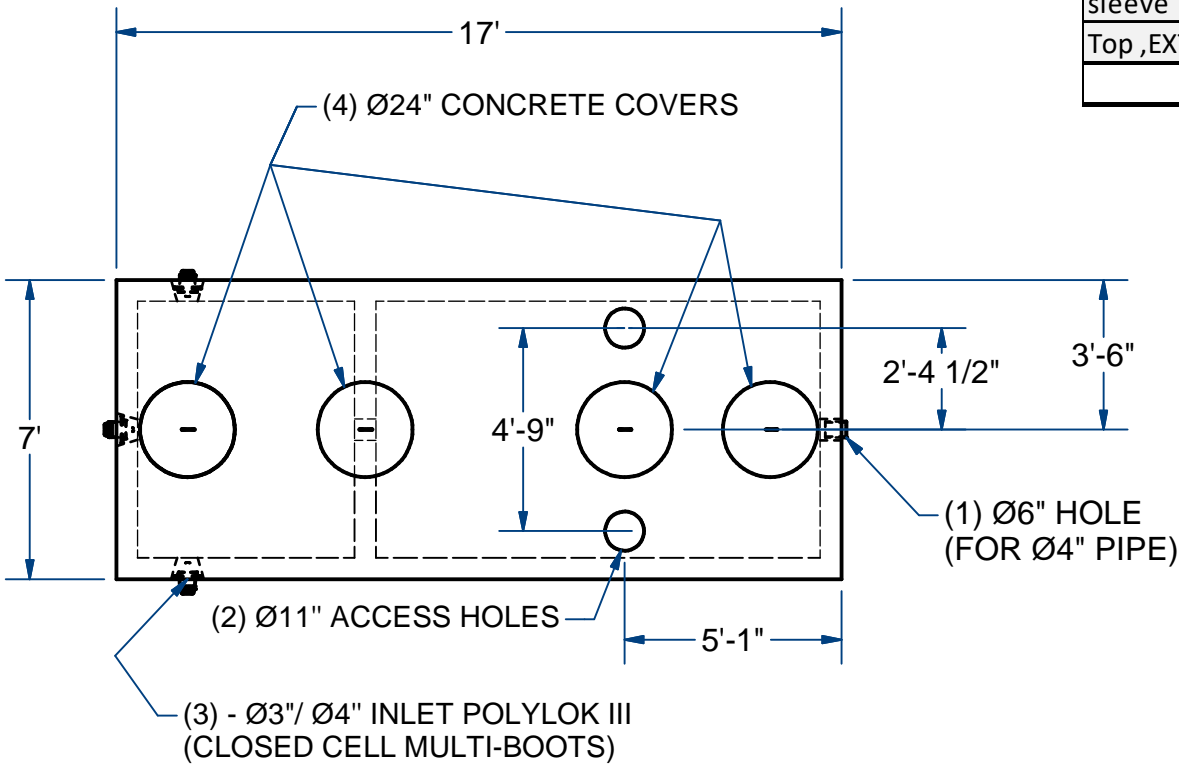

NAME: FAST TANK 1.5 INTERNAL MOUNT
(2- COMPARTMENT)

H-20

ITEM# FTIM1.5

Concrete Minimum Strength: 5,000 p.s.i. at 28 days
Steel Reinforcement: ASTM A615, Grade 60
Design Loading: standard units - AASHTO - H20

WEIGHT 45,000 Lbs

C

DATE: 1-5-2023

Ch 14 Pg 2.3 Sht 2 of 2