

ACME-SHOREY

PRECAST CONCRETE PRODUCTS

WWW.ACME-SHOREY.COM

PHONE (508) 548-9607

FAX (508) 548-1664

CARVER, MA
334 TREMONT STREET

HARWICH, MA
36 GREAT WESTERN ROAD

NOTES:

- 1.) SEAM SEALED WITH FLEXIBLE BUTYL RUBBER SEALANT.

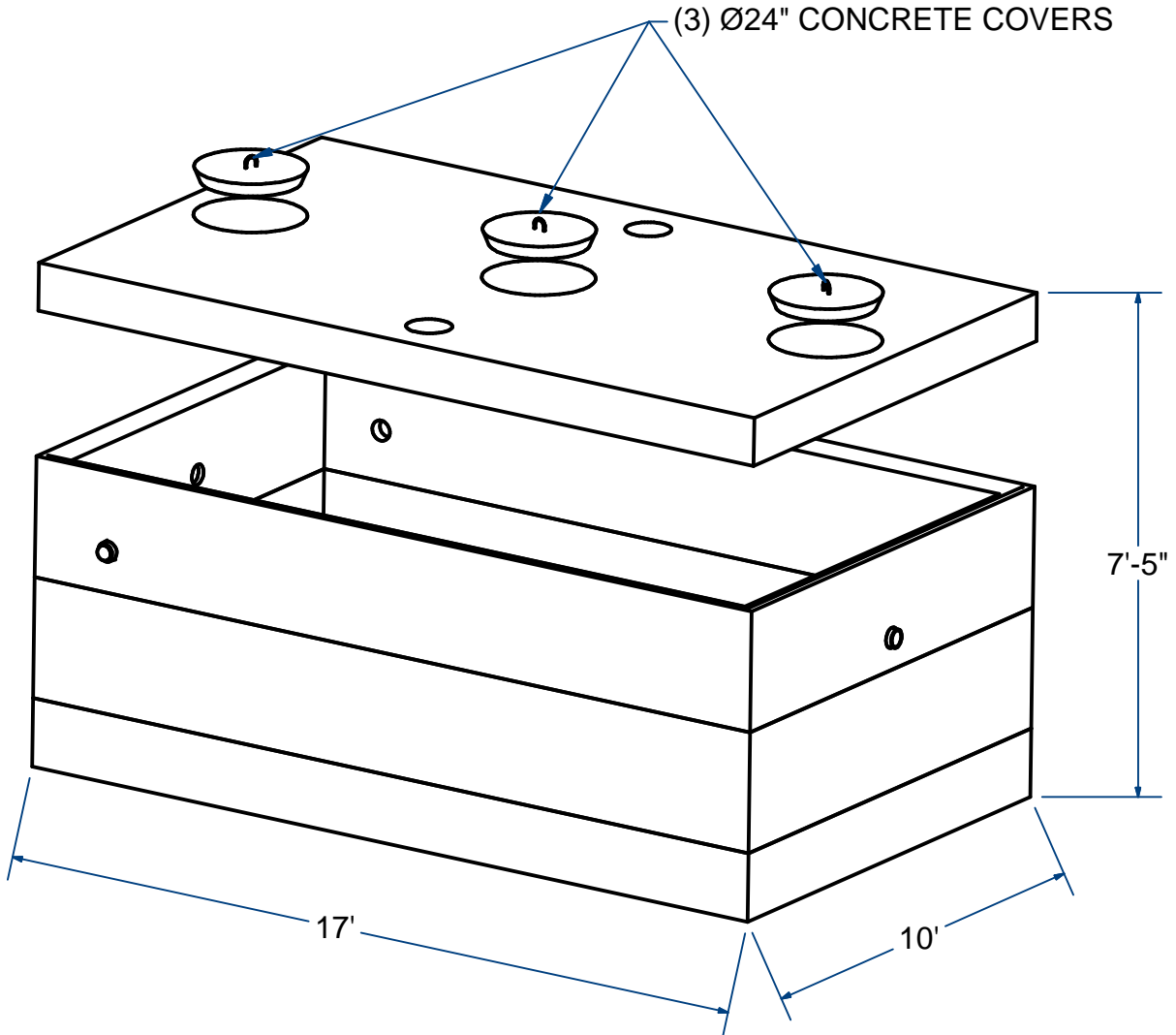

FOR PROCESS INFO
PLEASE CONTACT:

BIO-MICROBICS **FAST** wastewater
(800) 753-3278 treatment systems
with SFR.

DISTRIBUTOR:
J&R Sales & Service
Raynham, Ma. 02767
(508) 823-9566
www.jrsalesinc.com

FAST TANK 4.5

INTERNAL MOUNT

H20

ITEM# FTIM4.5

Wt. 64,900 Lbs

14-2.5

Sht 1 of 2

ACME-SHOREY

PRECAST CONCRETE PRODUCTS

NOTES:

- 1.) SEAM SEALED WITH FLEXIBLE BUTYL RUBBER SEALANT.

Each Section	Wt ea. (Lbs)
Base 1'-7"	22,000
Sleeve #1 - 30"	10,800
K.O. Sleeve#2 - 30"	10,500
Top 10"	21,600
	64,900

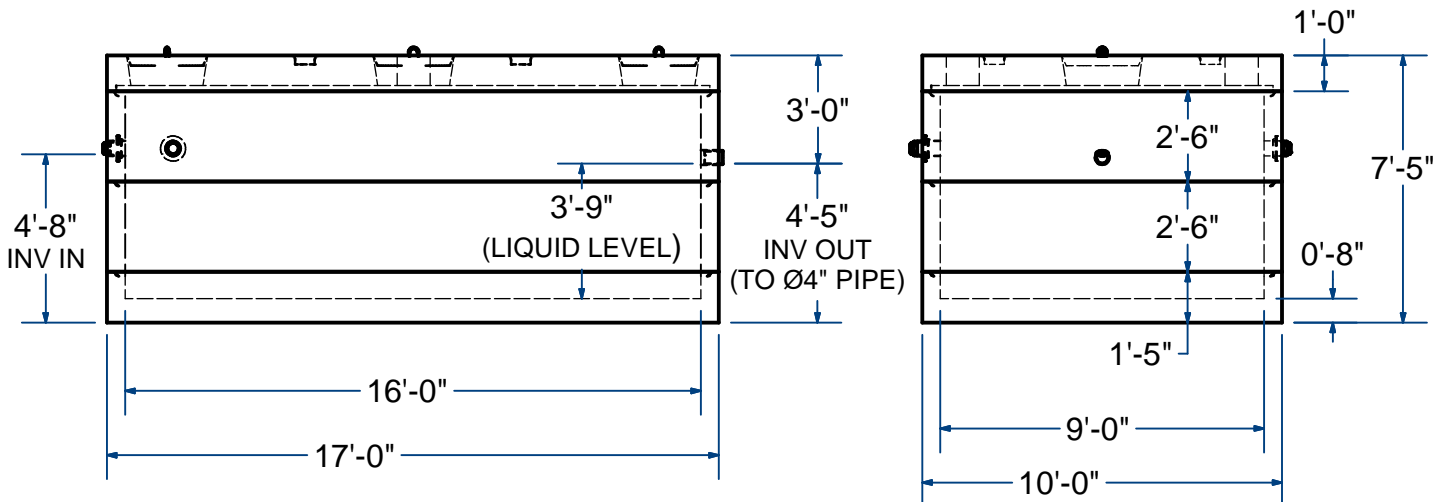
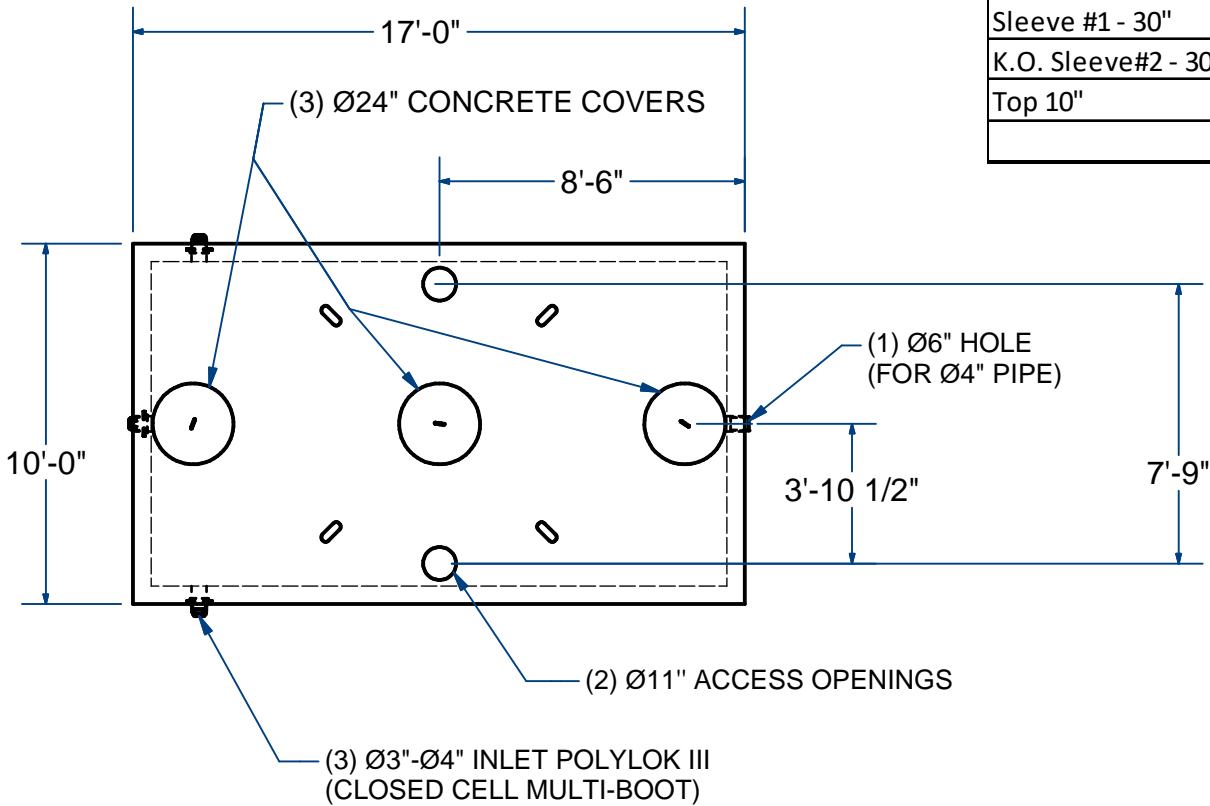

PRECAST TANK HAS 4,218 GALLON CAPACITY @ 3'-11" Ht.

NAME: FAST TANK 4.5, INTERNAL MOUNT
(SINGLE COMPARTMENT)

H-20

ITEM# FTIM4.5

Concrete Minimum Strength: 5,000 p.s.i. at 28 days
Steel Reinforcement: ASTM A615, Grade 60
Design Loading: standard units - AASHTO - H20

TANK Wt. 64,900 Lbs

H

DATE: 1-4-23

Ch 14 Pg 2.5 Sht 2 of 2