

ACME-SHOREY

PRECAST CONCRETE PRODUCTS

WWW.ACME-SHOREY.COM

PHONE (508) 548-9607

FAX (508) 548-1664

CARVER, MA

334 TREMONT STREET

HARWICH, MA

36 GREAT WESTERN ROAD

NOTES:

- 1.) SEAM SEALED WITH FLEXIBLE BUTYL RUBBER SEALANT.

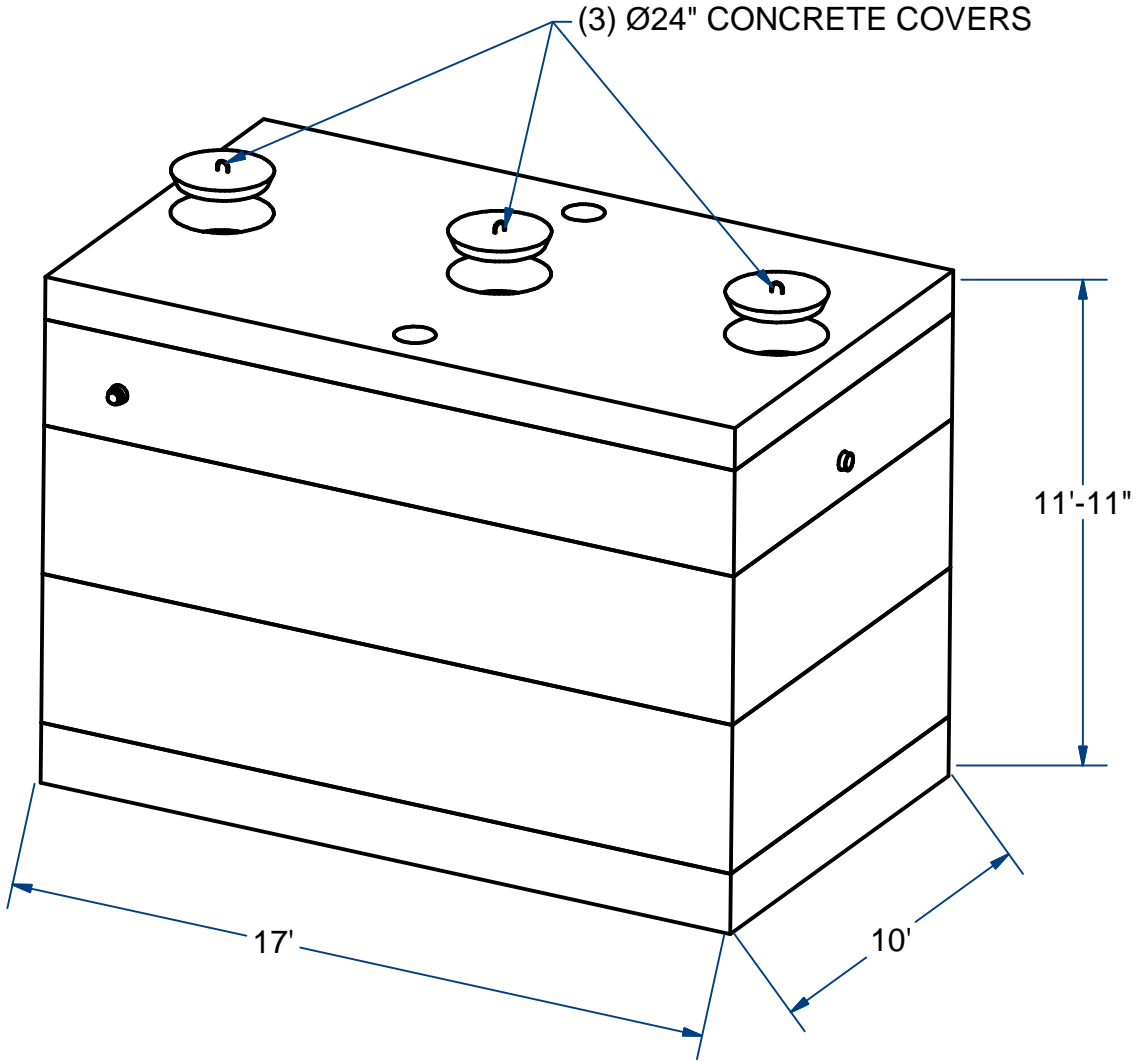

FOR PROCESS INFO
PLEASE CONTACT:

BIO-MICROBICS **FAST** wastewater treatment systems
(800) 753-3278 with SFR.

DISTRIBUTOR:
J&R Sales & Service
Raynham, Ma. 02767
(508) 823-9566
www.jrsalesinc.com

FAST TANK 9.0

INTERNAL MOUNT

H20

ITEM# FTIM9.0

Wt. 82,250 Lbs

14-2.6

Sht 1 of 2

ACME-SHOREY

PRECAST CONCRETE PRODUCTS

NOTES:

- 1.) SEAM SEALED WITH FLEXIBLE BUTYL RUBBER SEALANT.
- 2.) NO SPANNERS ACCROSS WALLS (TO FIT FAST TANK UNIT)

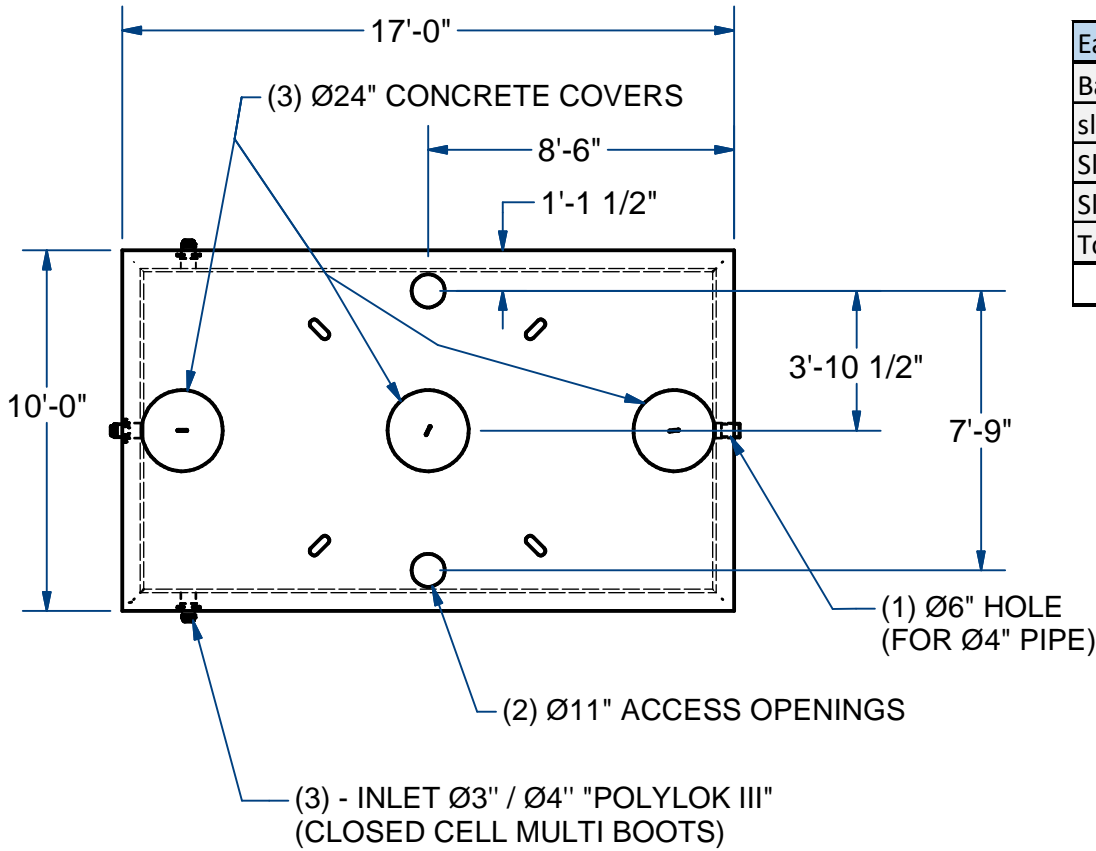

Each Sect.	Ht.	Wt (Lbs)
Base	17"	21,500
sleeve#1	42"	14,500
Sleeve#2	42"	14,500
Sleeve#3	30"	10,500
Top 10" Thk	12"	21,250
		82,250

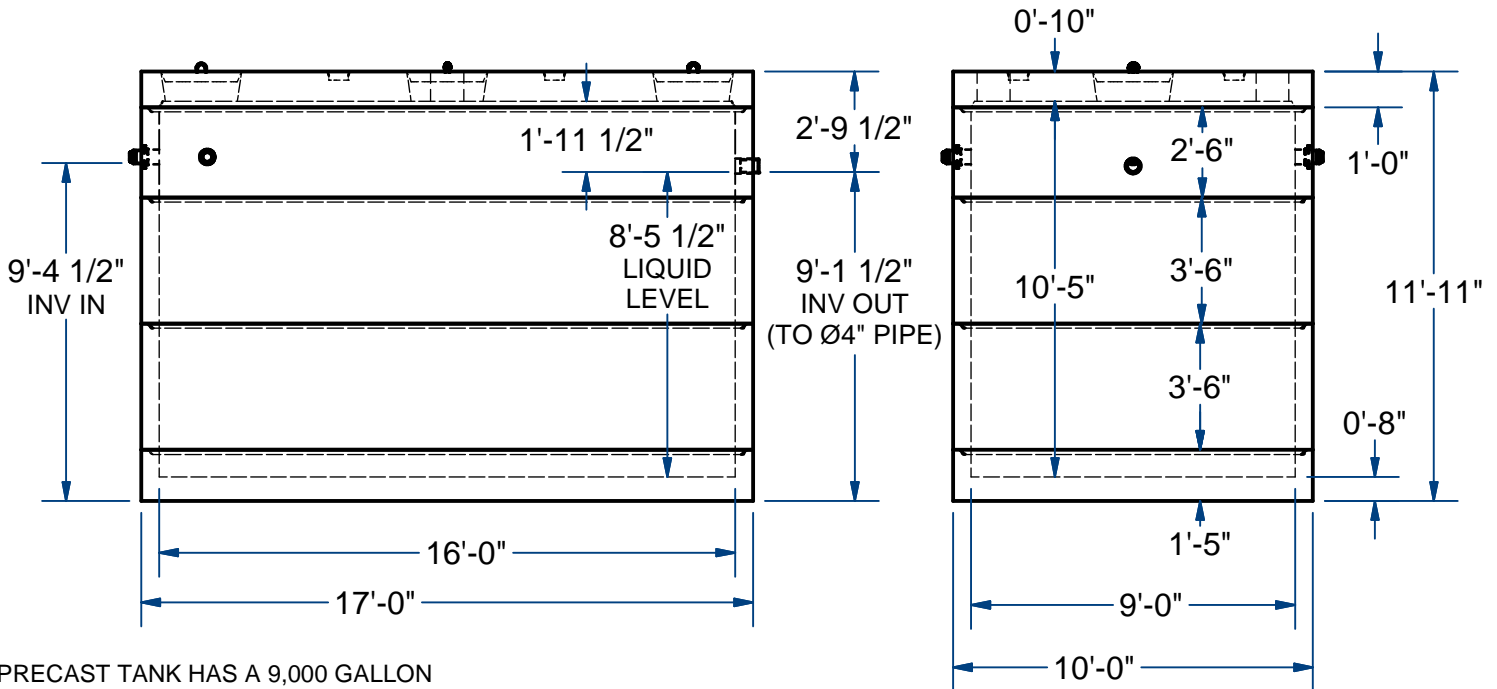

PRECAST TANK HAS A 9,000 GALLON CAPACITY @8'-5" Ht.

NAME: FAST TANK 9.0, INTERNAL MOUNT
(SINGLE COMPARTMENT)

H-20 ITEM# FTIM9.0

Concrete Minimum Strength: 5,000 p.s.i. at 28 days
Steel Reinforcement: ASTM A615, Grade 60
Design Loading: standard units - AASHTO - H20

WEIGHT 82,250 Lbs

H DATE: 1-6-23

Ch 14 Pg 2.6 Sht 2 of 2