

ACME-SHOREY

PRECAST CONCRETE PRODUCTS

WWW.ACMESHOREY.COM

PHONE (508) 548-9607

FAX (508) 548-1664

CARVER, MA
334 TREMONT STREET

HARWICH, MA
36 GREAT WESTERN ROAD

NOTES:

- 1.) SEAM SEALED WITH FLEXIBLE BUTYL RUBBER SEALANT.

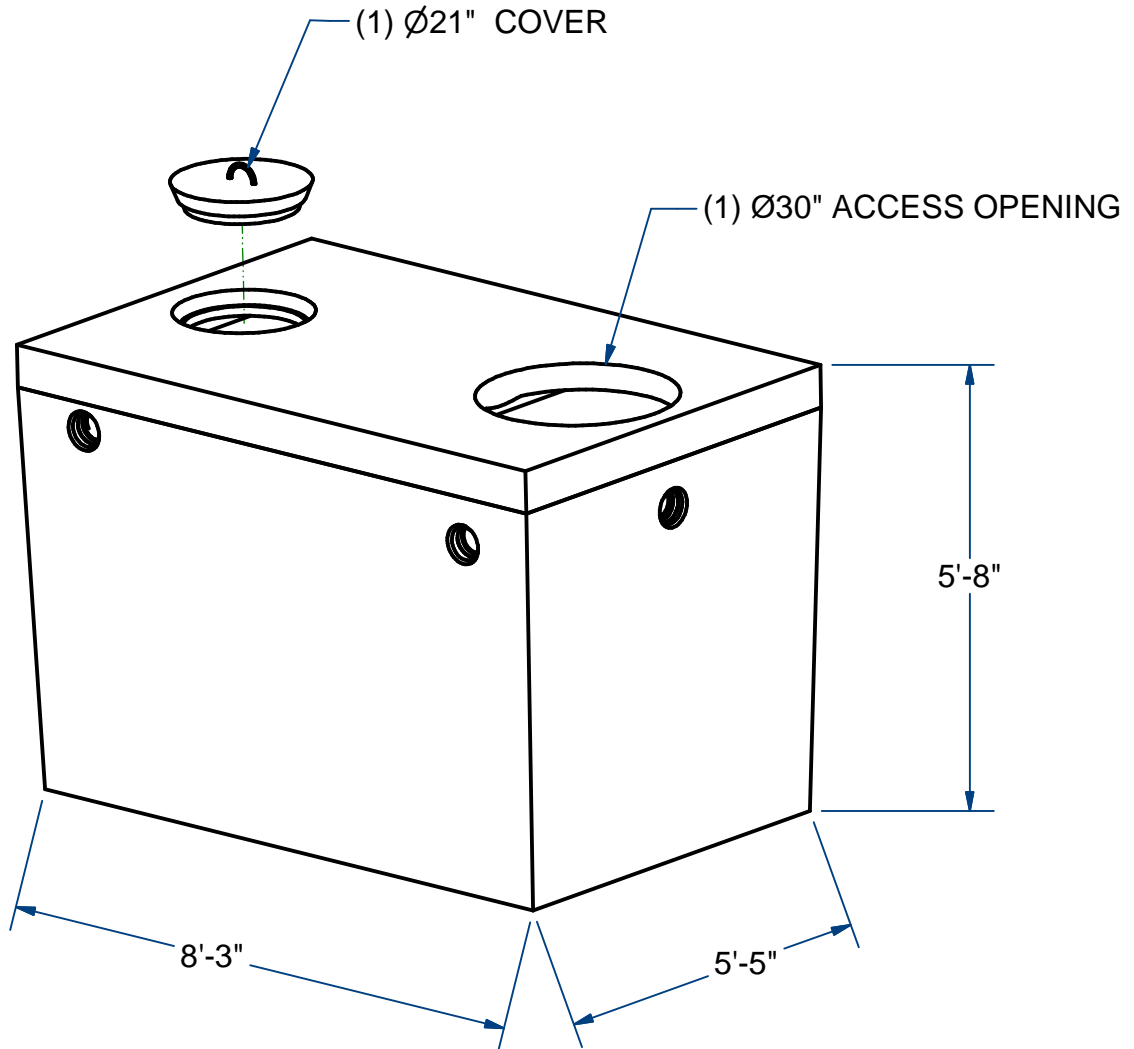

PUMP CHAMBER MONOLITHIC

H10

1000 GALLON

ITEM# PC10M30

Wt. 8,200 Lbs

2 -2.2

Sht 1 of 2

ACME-SHOREY

PRECAST CONCRETE PRODUCTS

NOTES:

- 1.) SEAM SEALED WITH FLEXIBLE BUTYL RUBBER SEALANT.

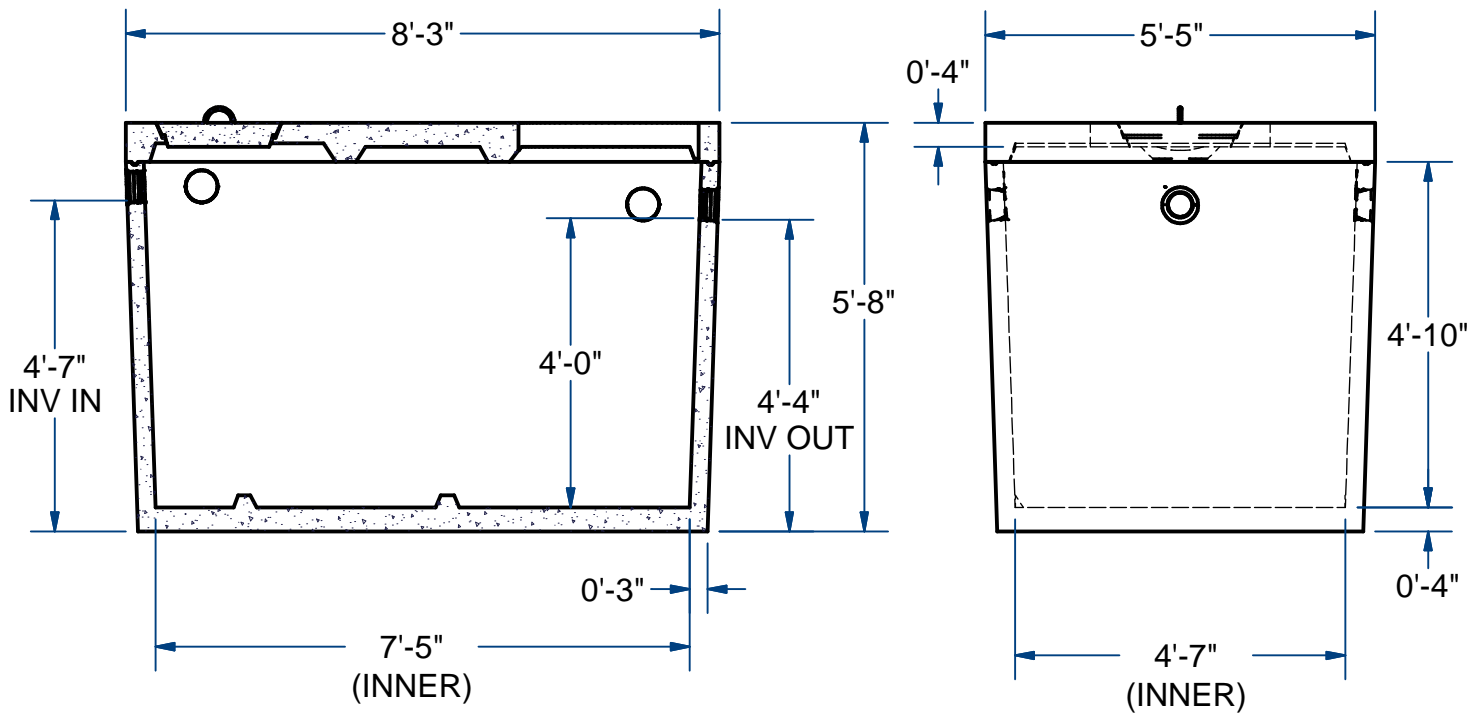
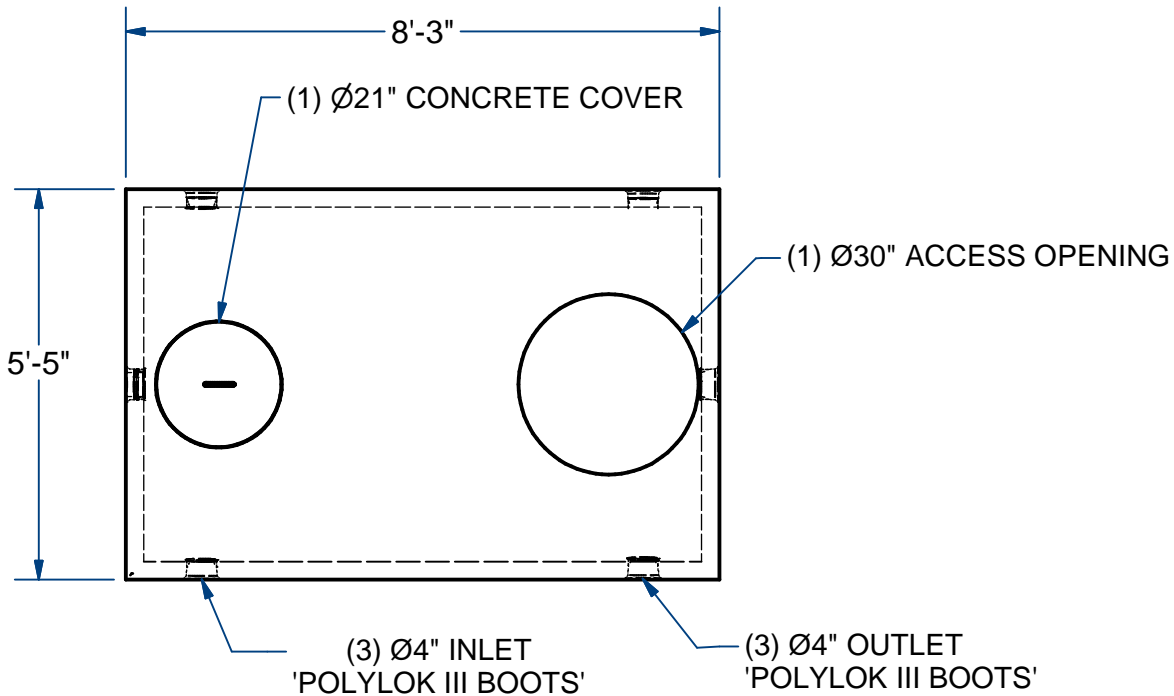

NAME: PUMP CHAMBER, 1000 Gallon, MONO

H-10

ITEM# PC10M30

Concrete Minimum Strength: 4,000 p.s.i. at 28 days
 Steel Reinforcement: ASTM A615, Grade 60
 Design Loading: standard units - AASHTO - H10

TOP 2,200 Lbs
 BOTTOM 6,000 Lbs

S DATE: 9-24-2017
 Ch 2 Pg 2.2 Sht 2 of 2