

ACME-SHOREY

PRECAST CONCRETE PRODUCTS

WWW.ACMESHOREY.COM

PHONE (508) 548-9607

FAX (508) 548-1664

CARVER, MA
334 TREMONT STREET

HARWICH, MA
36 GREAT WESTERN ROAD

NOTES:

- 1.) SEAM SEALED WITH FLEXIBLE BUTYL RUBBER SEALANT.

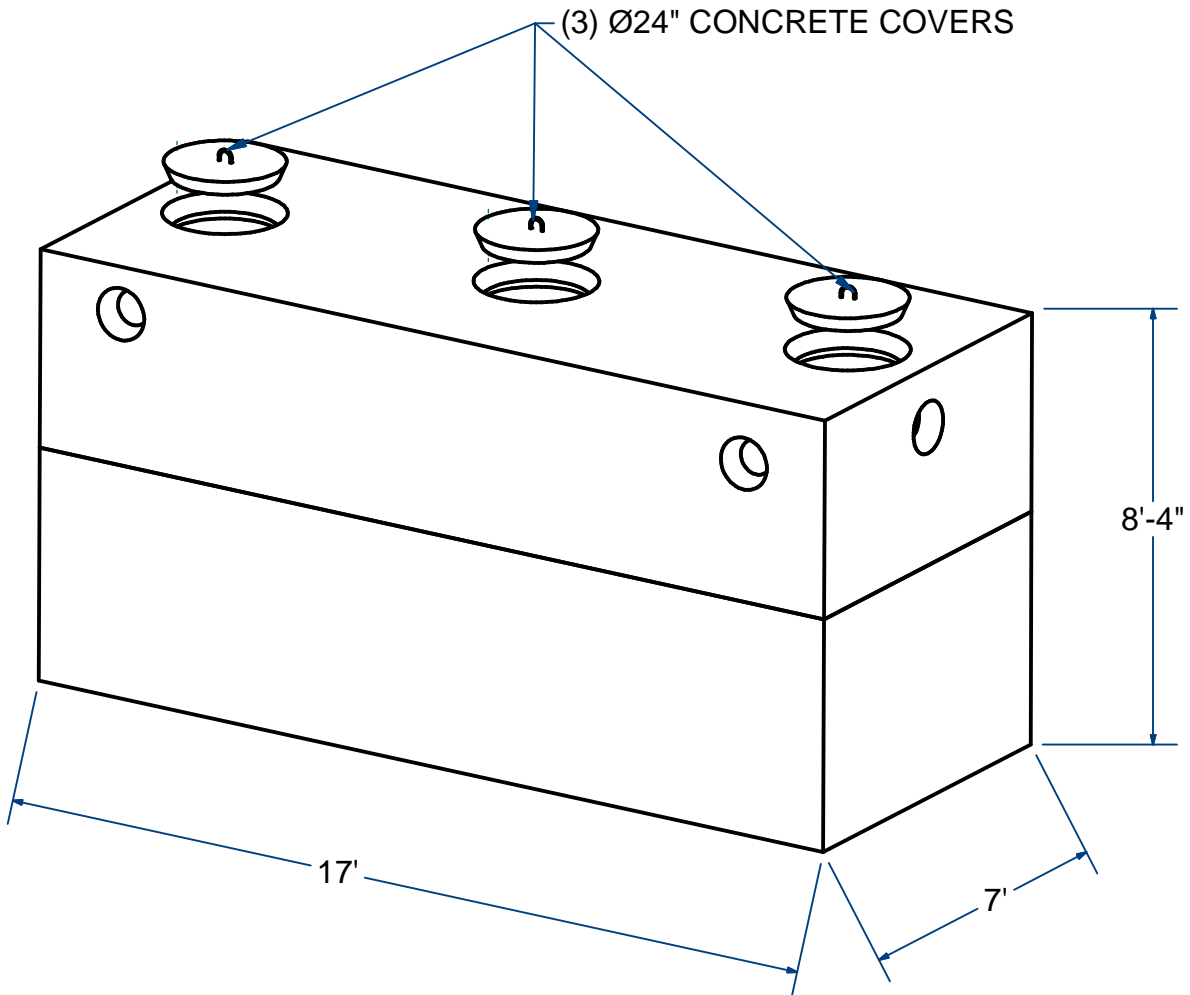

7'X17' SEPTIC TANK

4,500 Gallon

H20

ITEM# ST745H

Wt. 44,500 Lbs

8 -15.4

Sht 2 of 2

ACME-SHOREY

PRECAST CONCRETE PRODUCTS

NOTES:

- 1.) SEAM SEALED WITH FLEXIBLE BUTYL RUBBER SEALANT.

Each	Ht	wt.(Lbs)
Top	46"	20,500
Bottom	54"	24,000
		44500

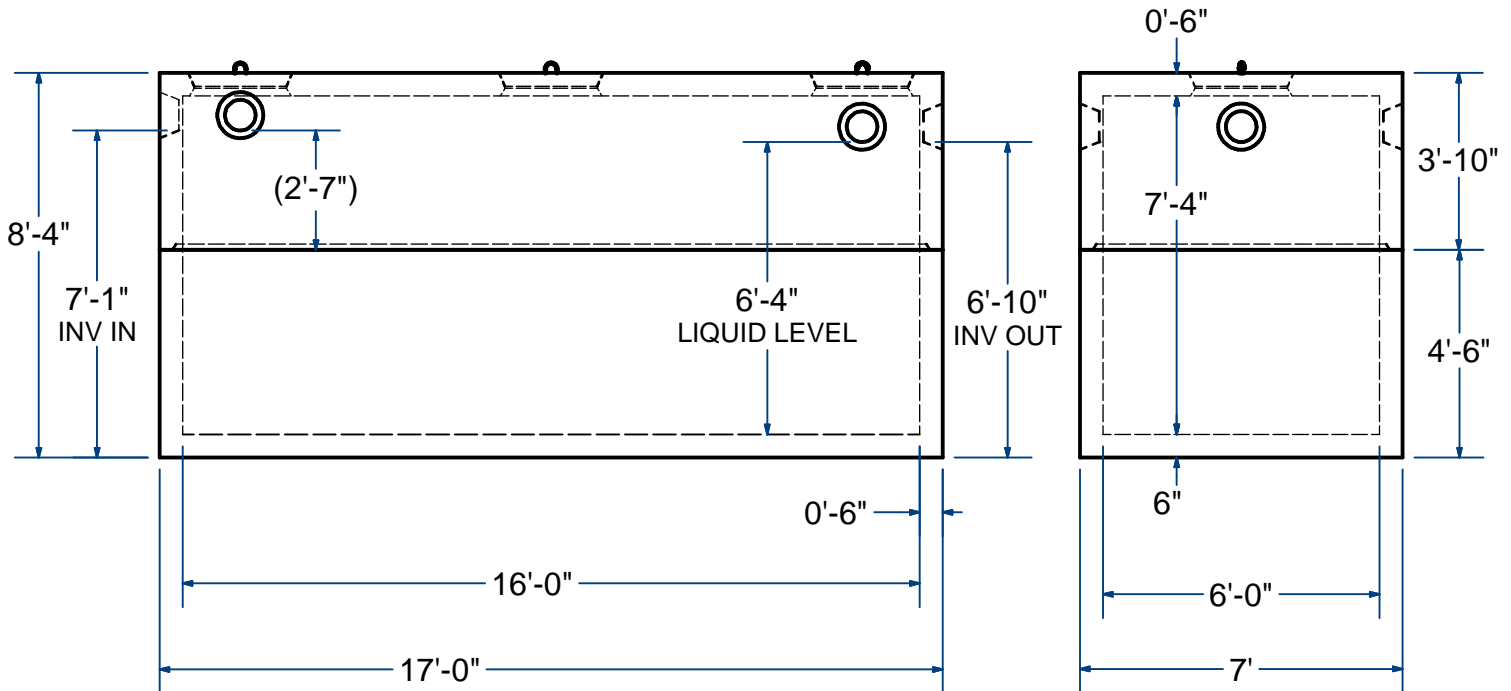
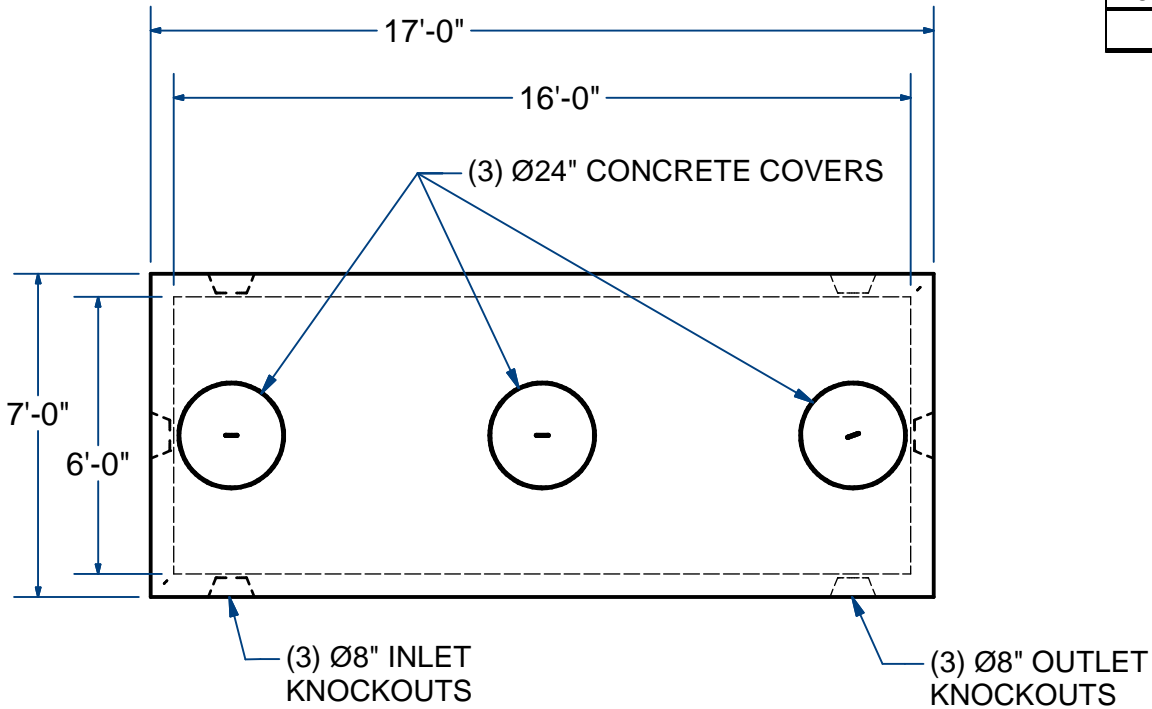

NAME: 7'X17' SEPTIC TANK, 4500 Gallon

H-20

ITEM# ST745H

Concrete Minimum Strength: 5,000 p.s.i. at 28 days
 Steel Reinforcement: ASTM A615, Grade 60
 Design Loading: standard units - AASHTO - H20

WEIGHT 44,500 Lbs

H

DATE: 1-9-23