

NOTES:
1.) SEAM SEALED WITH FLEXIBLE BUTYL RUBBER SEALANT.

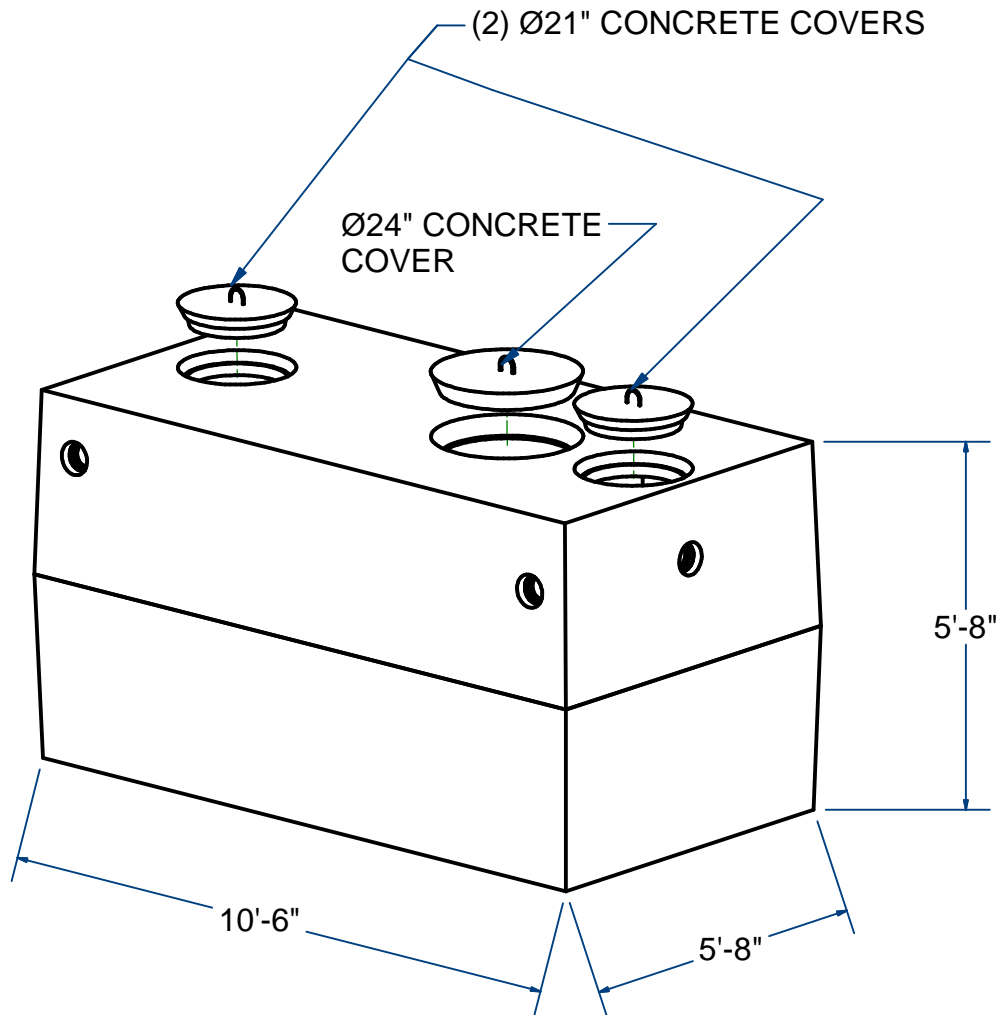

SEPTIC TANK -SEPTIC TANK

H10

1,500 GALLON

ACME-SHOREY

PRECAST CONCRETE PRODUCTS

NOTES:

- 1.) SEAM SEALED WITH FLEXIBLE BUTYL RUBBER SEALANT.

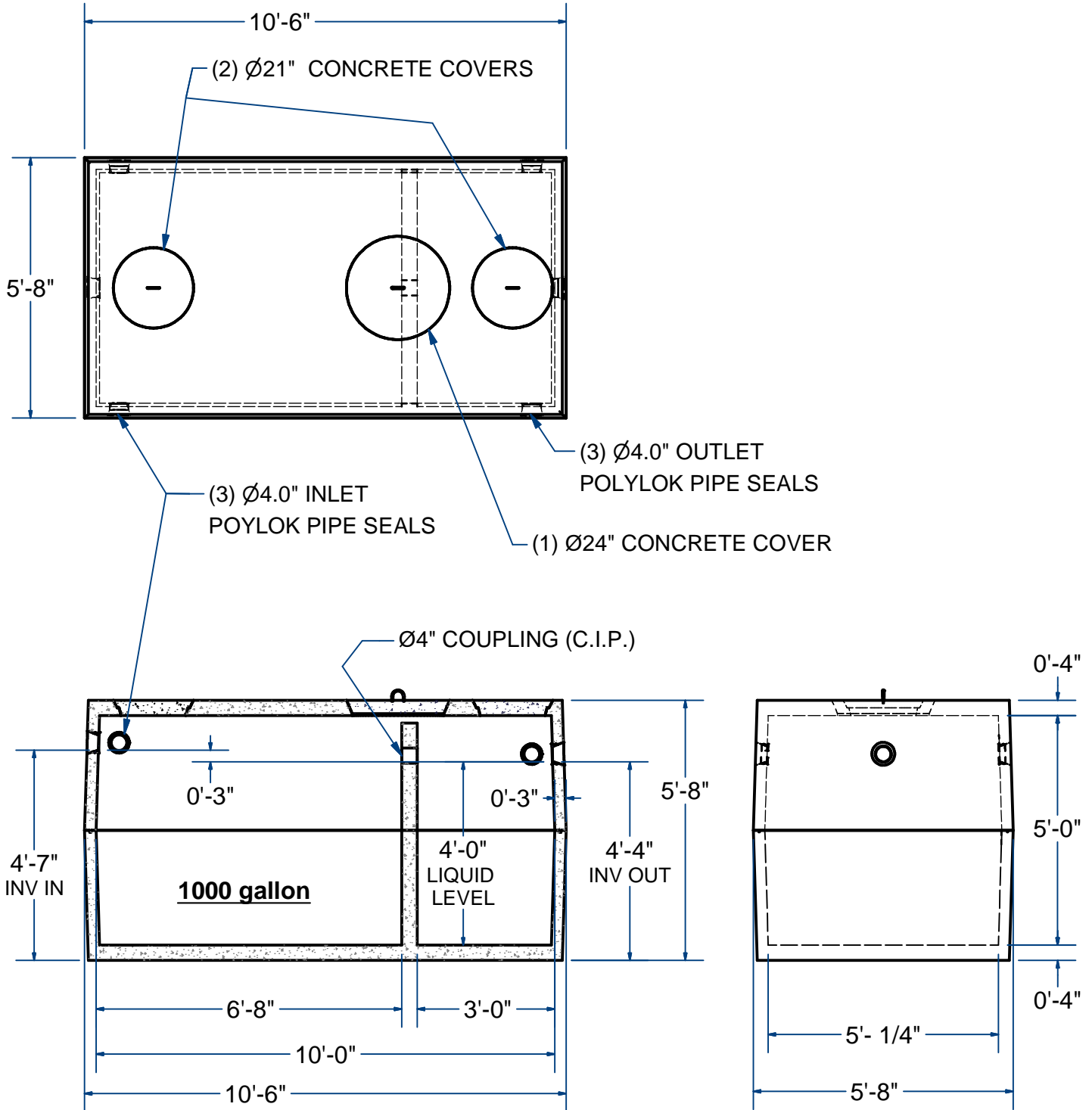

NAME: SEPTIC TANK-SEPTIC TANK, 1500Gallon H-10

ITEM# STST15

Concrete Minimum Strength: 4,000 p.s.i. at 28 days
 Steel Reinforcement: ASTM A615, Grade 60
 Design Loading: standard units - AASHTO - H10

TOP 6,500 Lbs
 BOTTOM 6,500 Lbs

CH

DATE: 3-20-19