

ACME-SHOREY

PRECAST CONCRETE PRODUCTS

WWW.ACME-SHOREY.COM

PHONE (508) 548-9607

FAX (508) 548-1664

CARVER, MA

334 TREMONT STREET

HARWICH, MA

36 GREAT WESTERN ROAD

NOTES:

- 1.) SEAM SEALED WITH FLEXIBLE BUTYL RUBBER SEALANT.
- 2.) STaar .75 Size USES A M550 PROCESSOR IN A $1^{250}/_{1500}$ GALLON TANK.
STaar 1.0 Size USES A M750 PROCESSOR IN A 1500 GALLON TANK.

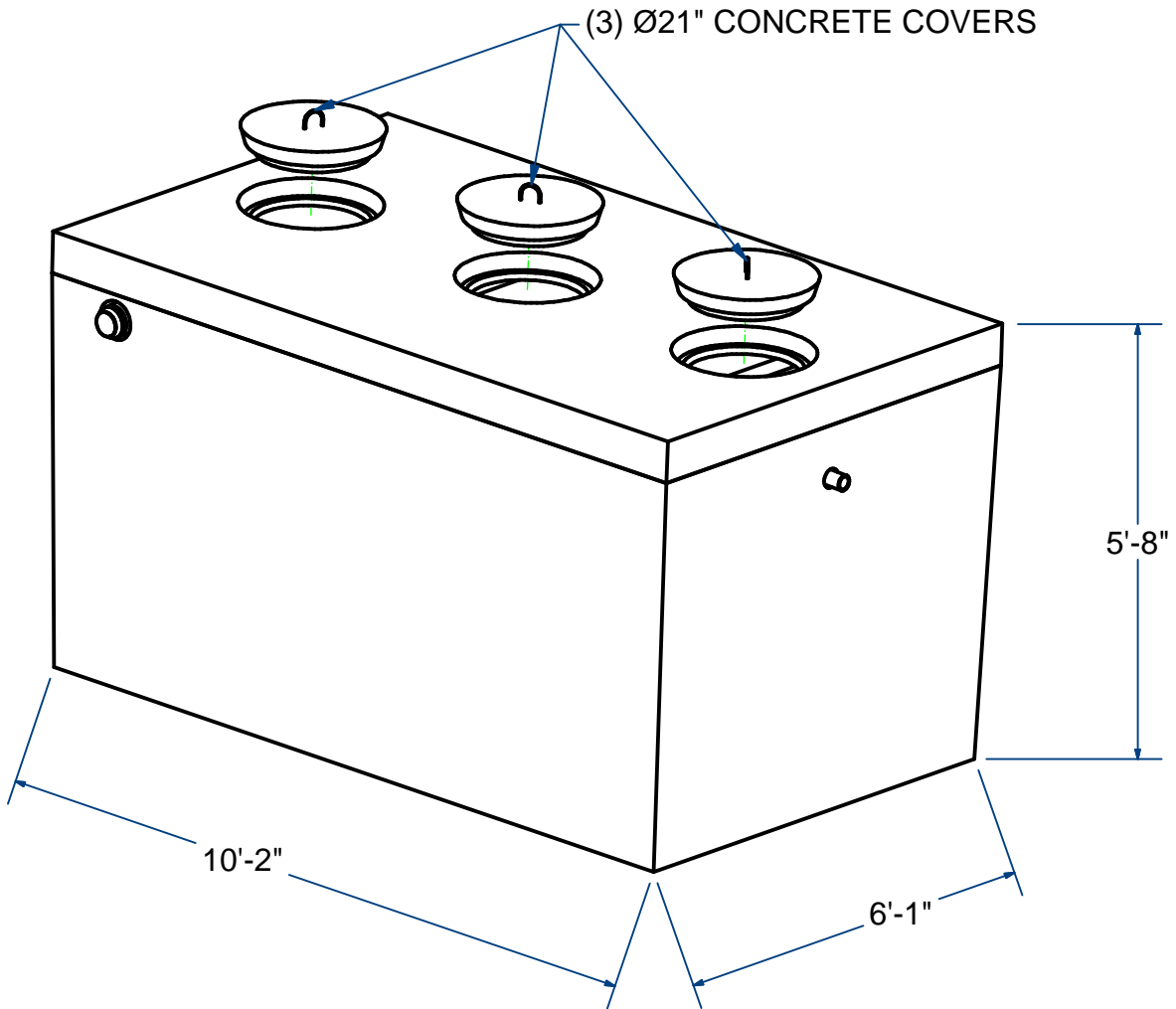

STaar SEPTIC TANK, (MODELS .75 OR 1.0), 2-COMPARTMENT

1,500 Gallon

H10

FOR PROCESS INFO
PLEASE CONTACT:

DISTRIBUTOR
J&R Sales & Service
Raynham, Ma 02767
(207) 333-6940
www.jrsalesinc.com

STaar
Smart Floating Aerobic/Serobic Retention Filter Systems
SeptiTech
a subsidiary of BioMicrobics, Inc.

ITEM# **STaar15M**

Wt. 13,600 Lbs

7 -6.2

Sht 1 of 2

ACME-SHOREY

PRECAST CONCRETE PRODUCTS

NOTES:

- 1.) SEAM SEALED WITH FLEXIBLE BUTYL RUBBER SEALANT.
- 2.) STaar .75 Size USES A M550 PROCESSOR IN A ¹²⁵⁰/₁₅₀₀ GALLON TANK.
STaar 1.0 Size USES A M750 PROCESSOR IN A 1500 GALLON TANK.

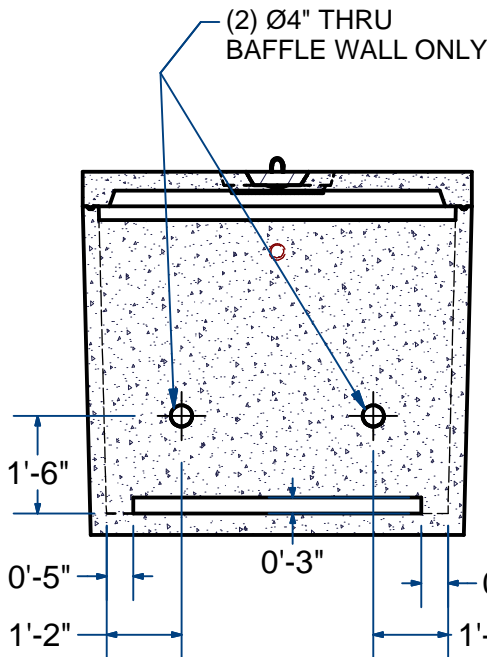
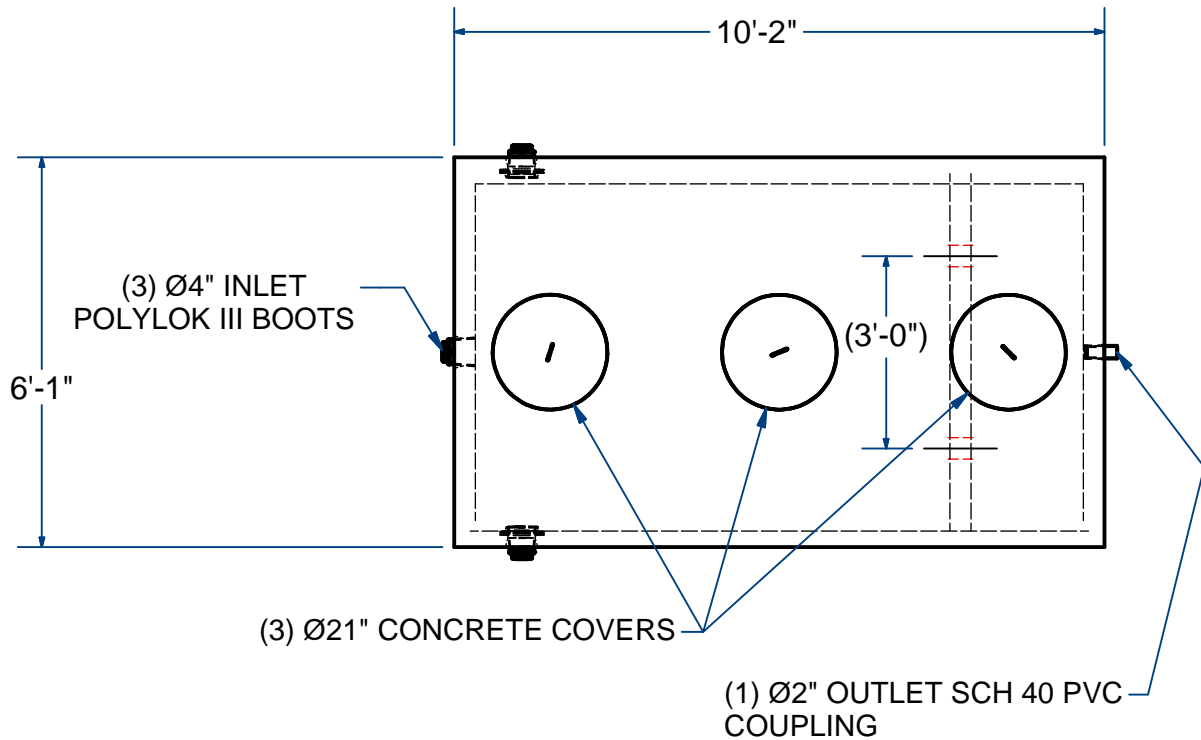

VIEW BAFFLE WALL

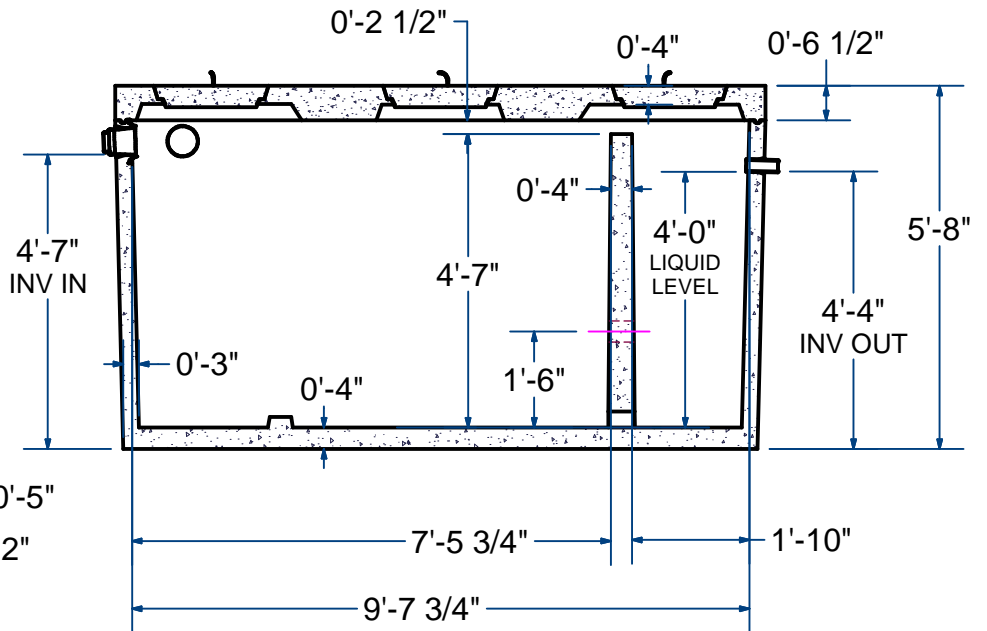

NAME: STaar 1.0 SEPTIC TANK, 1500 Gallon., MONO
(ACCOMODATES MODELS STaar.75 OR 1.0)

H-10

ITEM# STaar15M

Concrete Minimum Strength: 4,000 p.s.i. at 28 days
Steel Reinforcement: ASTM A615, Grade 60
Design Loading: standard units - AASHTO - H10

TOP 3,600 Lbs
BOTTOM 10,000 Lbs

H

DATE: 5-11-2020