

ACME-SHOREY

PRECAST CONCRETE PRODUCTS

WWW.ACMESHOREY.COM

PHONE (508) 548-9607

FAX (508) 548-1664

CARVER, MA
334 TREMONT STREET

HARWICH, MA
36 GREAT WESTERN ROAD

NOTES:

- 1.) SEAM SEALED WITH FLEXIBLE BUTYL RUBBER SEALANT.

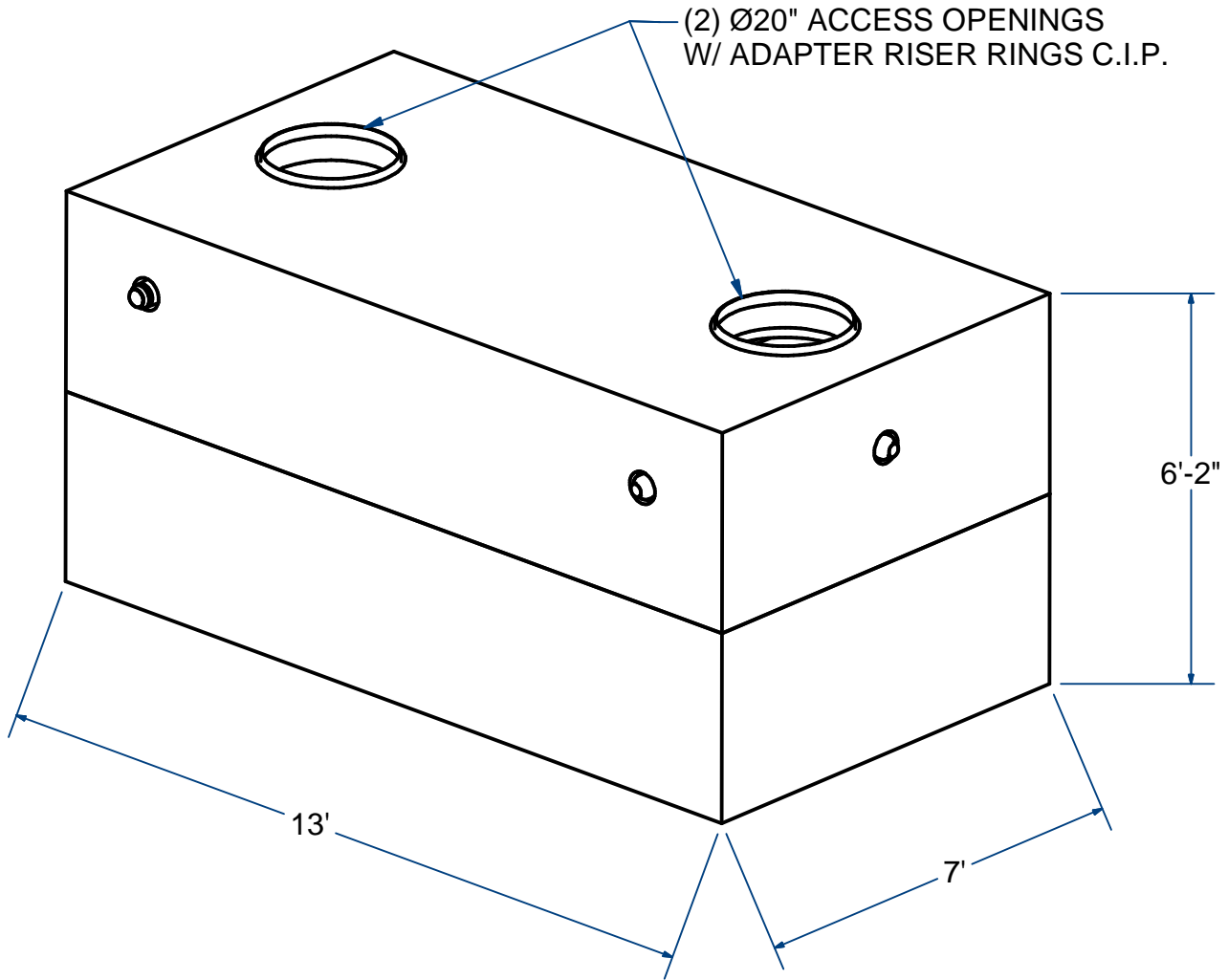

WATERLOO BIOFILTER TANK (2-COMPARTMENT)

2,000 Gallon

H2O

FOR PROCESS INFO
PLEASE CONTACT:



(866) 366-4329
info@waterloo-biofilter.com
www.waterloo-biofilter.com

ITEM# **WBSTPC1552**

Wt. 31,500 Lbs

14-6.1

Sht 1 of 2

ACME-SHOREY

PRECAST CONCRETE PRODUCTS

NOTES:

1.) SEAM SEALED WITH FLEXIBLE BUTYL RUBBER SEALANT.

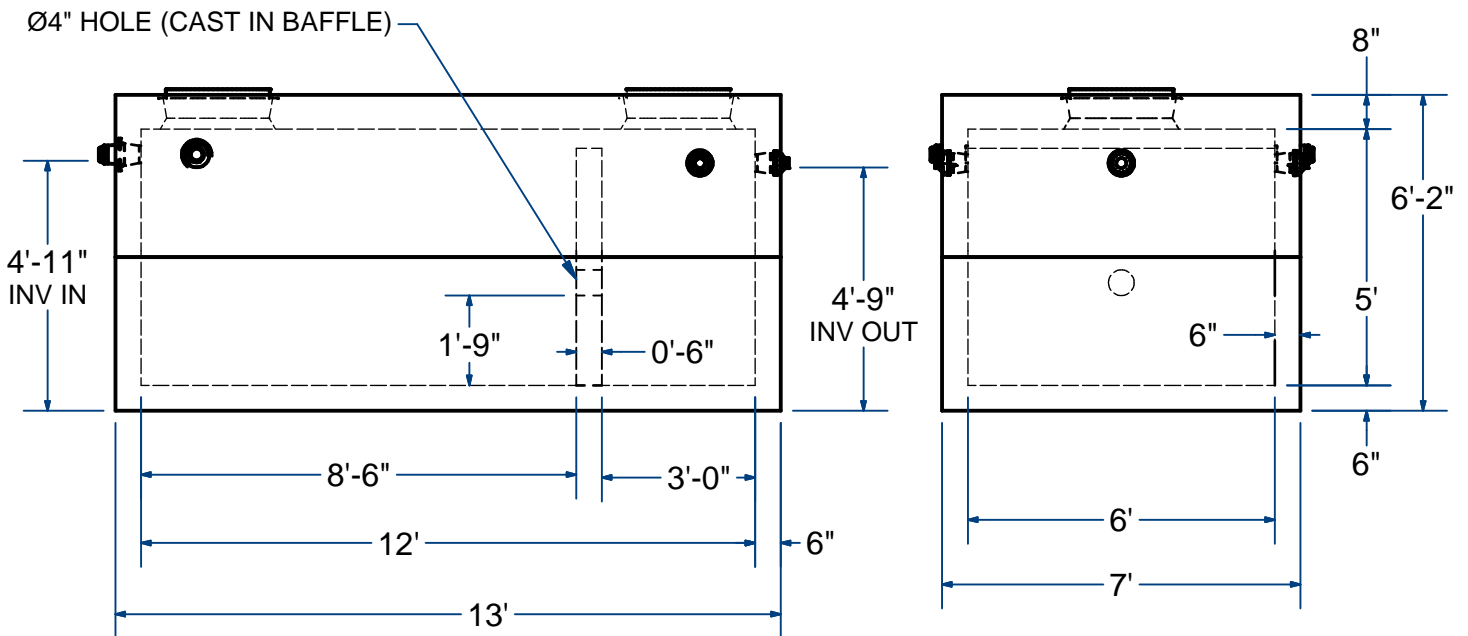
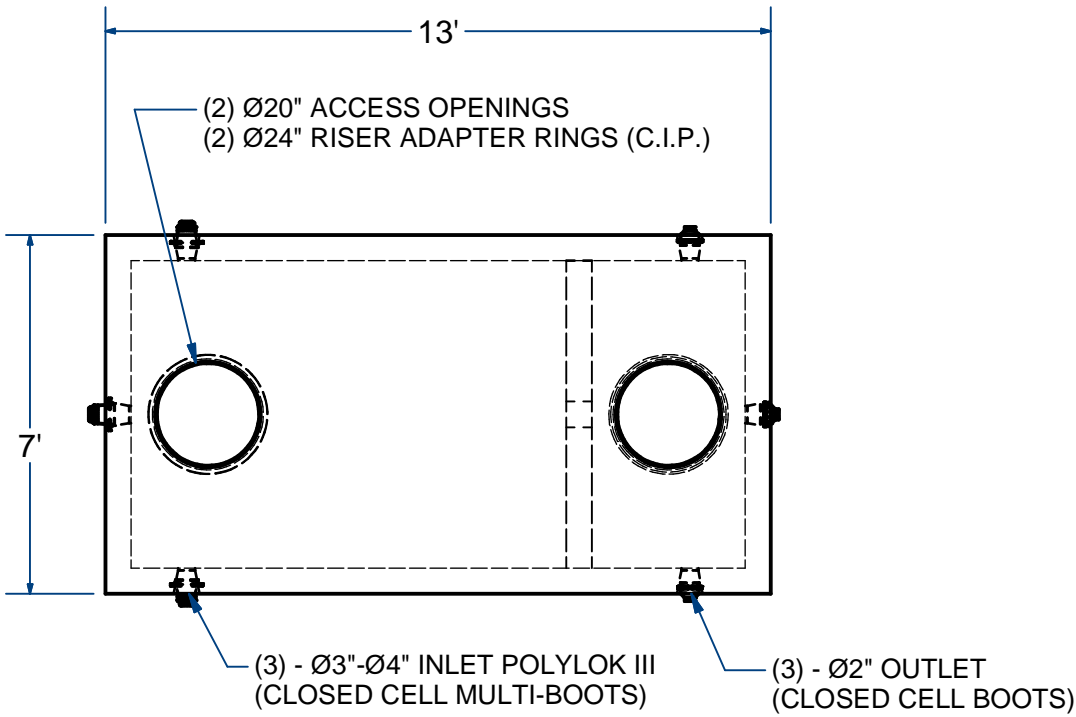

NAME: WATERLOO BIOFILTER TANK, 2000 Gallon

H-20

ITEM# WBSTPC1552

Concrete Minimum Strength: 5,000 p.s.i. at 28 days
 Steel Reinforcement: ASTM A615, Grade 60
 Design Loading: standard units - AASHTO - H20

TOP 16,250 Lbs
 BOTTOM 15,250 Lbs

C

DATE: 2-19-19

Ch 14 Pg 6.1 Sht 2 of 2